



**Astro Pneumatic
Tool Company**

372 Old US Highway 52 South
Mount Airy, NC 27030

Model:

3050

Product Type:

**COMPLETE DUAL ACTION SANDING
& POLISHING KIT**

Call 1.800.221.9705 for questions concerning performance of the product or other inquiries.

PARTS BREAKDOWN

FOR 3042 Pistol Grip Dual Action Sander/Polisher Tool

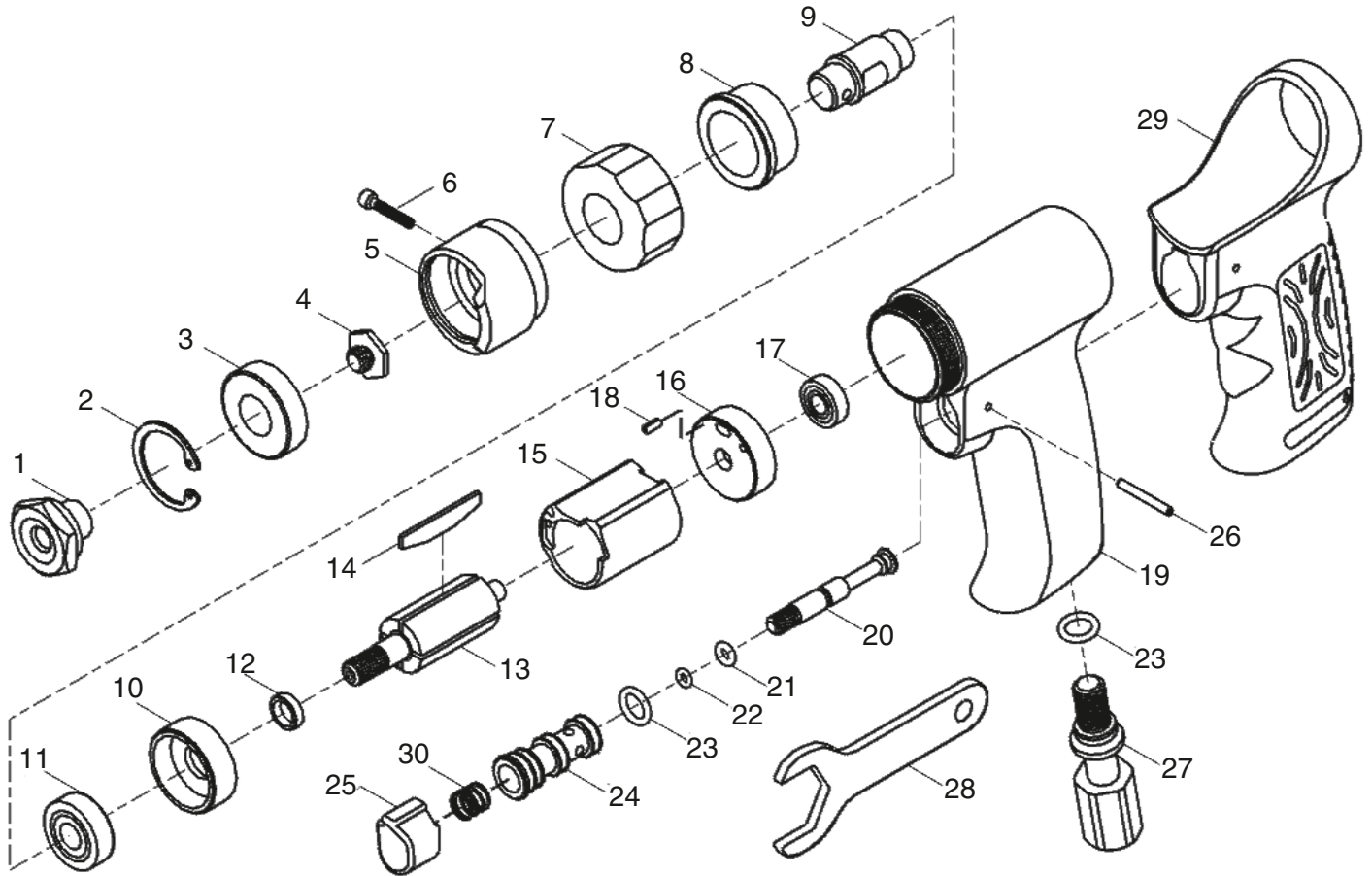

Parts List

Index No.	Part No.	Description	Qty
1	3042-01	Spindle	1
2	3042-02	Retaining Ring	1
3	3042-03	Ball Bearing	1
4	3042-04	Hex Screw	1
5	3042-05	Balancer	1
6	3042-06	Screw	1
7	3042-07	Clamp Housing	1
8	3042-08	Bushing	1
9	3042-09	Rotor Shaft	1
10	3042-10	Front End Plate	1
11	3042-11	Ball Bearing	1
12	3042-12	Rotor Collar	1
13	3042-13	Rotor	1
14	3042-14	Vane	4
15	3042-15	Cylinder	1

Index No.	Part No.	Description	Qty
16	3042-16	Rear End Plate	1
17	3042-17	Ball Bearing	1
18	3042-18	Pin	1
19	3042-19	Motor Housing	1
20	3042-20	Valve Stem	1
21	3042-21	O-Ring	1
22	3042-22	O-Ring	1
23	3042-23	O-Ring	3
24	3042-24	Valve Bushing	1
25	3042-25	Button Trigger	1
26	3042-26	Pin	1
27	3042-27	Inlet Bushing	1
28	3042-28	Spanner	1
29	3042-29	Housing Sleeve	1
30	3042-30	Spring	1



Model: **3050**

Product Type:

COMPLETE DUAL ACTION SANDING & POLISHING KIT

Foreseen Use of the Tool

Do not use the tool outside of the design intent.
Never modify the tool for any other purpose, or for its use.



Safety Precaution

Caution: To help prevent personal injury

- Normal use of this product is likely to expose the user to dust and/or microscopic particles containing chemicals known to the State of California to cause cancer, birth defects or other reproductive harm. Always wear appropriate safety equipment and clothing when using this product. Study, understand and follow all instructions provided with this product.
- Always wear ANSI approved goggles when using this product.
- Always select the correct accessories of the correct size and design for the job that you are attempting to perform.
- Always work in a clean, safe, well-lit, organized and adequately equipped area.
- Do not begin repairs without assurance that vehicle is in secure position, and will not move during repair.



Astro Pneumatic Tool Company

www.astrotools.com

1 YEAR LIMITED WARRANTY

•Astro Pneumatic Tool Co. warrants our products to the original user against defective material or workmanship for a period of 1 year from the date of 1st use. Astro reserves the right to determine whether the product failed because of defective material, workmanship or other causes and to charge back for missing parts. Astro Pneumatic Tool Co., at its discretion, will repair products covered under this warranty free of charge. The original user is to return the product (with the exceptions listed below) with the distributor's name, address, adequate proof of date of purchase or a copy of warranty card, and a short note explaining the problem. **Failures caused by accident, alteration, or misuse are not covered by this warranty.**

•If one part of this product fails, please do not return the entire product. Astro will replace free of charge component parts of this product that fail within 1 year of first use by the original user. Items included in this category include but are not limited to kits, hand tool kits and any other product where there are multiple items or components that make up the unit. Please contact the phone number below in order to obtain the replacement components covered under warranty.

•Astro Pneumatic Tool Co. or its authorized service representatives must perform all warranty repairs. Any repair to the product by unauthorized service representatives voids this warranty. The rights under this warranty are limited to the original user and may not be transferred to subsequent owners.

•This warranty is in lieu of all other warranties, expressed or implied, including warranties of merchantability and fitness for a particular purpose. Some states do not allow the exclusion of limitations of incidental or consequential damages so the above limitations may not apply to you. All claims must be sent to:

Astro Pneumatic Tool Company
372 Old US Highway 52 South
Mt. Airy, NC 27030

Product Information

- Blow molded case for easy storage and transport
- Kit Includes:
Pistol Grip Dual Action Sander/Polisher Tool
- 13,000rpm - 16,000rpm (#3042)
1 - 3" Sanding/Polishing Back-up Pad (#20302P)
1 - 1-1/2" Velcro Holder (#20304P)
1 - 1-1/2" Sanding Pad (#20305P)
1 - 3" Polishing Foam Pad (#20306P)
2 - 3" 400 Grit Sanding Disc (#3400P)
2 - 3" 600 Grit Sanding Disc (#3600P)
2 - 3" 1000 Grit Sanding Disc (#31000P)
10 - 1-1/2" 2000 Grit Sanding Disc (#2000P)
1 - Spanner Wrench

SPECIFICATIONS:

Tool Weight: 1.32 lbs (0.6kg)
Overall Length: 5-1/2 ins (140 mm)
Avg. Air Consumption: 5 (cfm) / 140 (l/min)
Recommended Air Pressure: 90 psi (6.3 bar)
Minimum Hose Size: 3/8" in. (10 mm)

Important

Read these instructions carefully before installing, operating, servicing or repairing this tool. Keep these instructions in a safe accessible place.



PLEASE CALL 1-800-221-9705
FOR REPAIR AND RETURN INSTRUCTIONS



Unpacking

When unpacking, check the parts diagram and part number listing on pages 3-4 to make sure all parts are included. If any parts are missing or damaged, please call your distributor.

COMPLETE DUAL ACTION SANDING & POLISHING KIT





Model: **3050**

Product Type:

COMPLETE DUAL ACTION SANDING & POLISHING KIT

MAINTENANCE INSTRUCTION:

1.) LUBRICATION:

Before connection the hose, apply 4 to 5 drops of #60 spindle oil at the air inlet. After 3 to 4 hours of operation, oiling may be necessary again.

2.) TIGHTNESS OF PARTS:

Regularly check whether all connection parts are **fastened securely**. **Follow this procedure daily before beginning work.**

3.) CLEANING:

Dust may accumulate around spindle inside shield. It is recommended to remove the dust on a daily basis.

4.) STORAGE:

Avoid storing the tool in a location subject to high humidity. If the tool is left unused, the residual moisture inside the tool can cause rust. Before storing and after operation, oil the tool at the air inlet with spindle oil and run it for a short period.

5.) DISPOSAL:

Follow national legislation of waste disposal. Never drop into fire.

6.) ORDERING SERVICE PART:

For further operational and handling information or for replacement of parts and components, contact the sales agent from where you purchased the tool, or the service division of our company. *When ordering parts and components, give each part number, name and quantities.

Cautions for Use

- 1.) This tool is intended for polishing and sanding with all types of movement e.g. rotary, orbital and reciprocating, using coated abrasive product and bonnets of various soft materials and endless belts. Any other use is forbidden.
- 2.) Only use the polishing and sanding pads as recommended by the pad manufacturer.
- 3.) It is forbidden to use the grinding wheels and cut-off wheels on this tool.
- 4.) Ensure the max. operating speed of the pad is higher than the rated speed of the poser tool.
- 5.) Centrally adhere sanding disc to support pad.
- 6.) Always wear ANSI approved ear protection and safety glasses when using this tool. Gloves and protective clothing are recommended.
- 7.) Personal protection and dust collection devices shall be chosen according to the material being worked upon. Please consult provider of such devices.
- 8.) Release the start and stop device in case of failure of energy supply.
- 9.) Only use the lubricant recommended by the manufacturer

WARNING

- 1) The tool shall not be used in potentially explosive atmospheres.
- 2) Disconnect the air hose before changing or adjusting any inserted tools.
- 3) Before using tool, please confirm all couplings and plugs are fixed securely. Air hose that is under pressure may lash out when disconnected and could lead to serious injuries.
- 4) Prevent loose clothes, long hair or any other personal accessor ies from coming close to moving parts to reduce the risk of being caught, trapped or drawn into the rotating spindle.
- 5) Excessive high air pressure, that exceeds the maximum pressure may cause injuries to user.
- 6) Exposure to strong vibration for extended time may cause harm to operator.
- 7) Make sure of the rotation direction before starting the tool to reduce hazardous situations due to unexpected rotation direction.
- 8) Slip/Trip/Fall is a major reason of serious injury or death. Beware of excess hose left on the walking or work surface.
- 9) Wearing eye/face protector could reduce the danger to person from high speed splinters being emitted from the tool or work surface.
- 10) Wearing correct breathing protection will help avoid inhaling dust or handling debris from work process that can be harmful to your health.
- 11) High sound level can cause permanent hearing loss. Use hearing protection while operating tool.
- 12) Due to the material being processed, there may be a risk of explosion or fire. Be aware of work surface dangers prior to beginning work.
- 13) There is a risk of being cut due to high speed rotation. Do not touch high speed rotating disc.
- 14) This power tool is not insulated. If contact is made with an electric current, injury may occur.
- 15) Dust created by sanding, sawing, grinding, drilling and other related activities may expose the user to dust and/or microscopic particles that may contain chemicals known to the State of California to cause cancer, birth defects or other reproductive harm.

WARNING

Users of this tool should review the chemical composition of the work surface and any products used in conjunction with this tool for any such chemicals prior to engaging in any activity that creates dust and/or microscopic particles.

Users should obtain the Material Safety Data Sheets for all identified chemicals, either from the manufacturer or their employer, and proceed to study, understand, and follow all instructions and warnings for exposure to such chemicals.

Some examples of these chemicals are: lead from lead based paints; crystalline silica from bricks, cement and other masonry products; and arsenic and chromium from chemically treated lumber. A listing of the chemicals can be obtained at www.oehha.ca.gov under Proposition 65.

In order to reduce their exposure to such chemicals users should always:

- work in well-ventilated areas .
- wear appropriate safety equipment and clothes that are specifically designed to filter out microscopic particles



**Astro Pneumatic
Tool Company**

372 Old US Highway 52 South
Mount Airy, NC 27030

Model:

3050

Product Type:

**COMPLETE DUAL ACTION SANDING
& POLISHING KIT**

**PARTS BREAKDOWN
FOR 3050**

Call 1.800.221.9705 for questions concerning performance of the product or other inquiries.

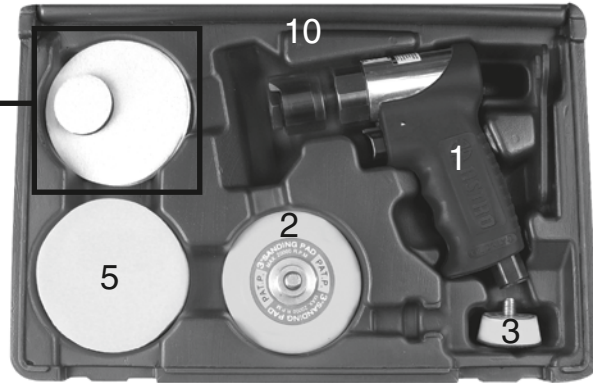
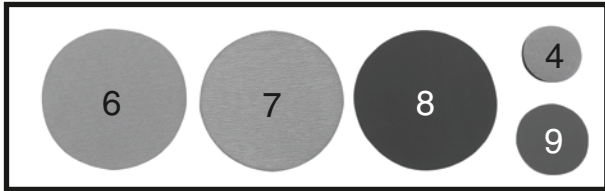

Parts List

Index No.	Part No.	Description	Qty
1	3042	Pistol Grip Dual Action Sander/Polisher Tool - 13,000rpm - 16,000rpm	1
2	20302P	3" Sanding/Polishing Back-up Pad	1
3	20304P	1-1/2" Velcro Holder	1
4	20305P	1-1/2" Sanding Pad	1
5	20306P	3" Polishing Foam Pad	1
6	3400P	3" 400 Grit Sanding Disc	2
7	3600P	3" 600 Grit Sanding Disc	2
8	31000P	3" 1000 Grit Sanding Disc	2
9	2000P	1-1/2" 2000 Grit Sanding Disc	10
10	K-2077-1B	Blow Molded Case	1

SUGGESTED AIR LINE CONNECTION

